



**Review of conditioning factors and  
constraints to legume adoption, and  
their management in Phase II of  
N2Africa**

Andrew Farrow

Submission date: 6 March 2014

**N2Africa**

**Putting nitrogen fixation to work  
for smallholder farmers in Africa**



N2Africa is a project funded by The Bill & Melinda Gates Foundation by a grant to Plant Production Systems, Wageningen University who lead the project together with CIAT-TSBF, IITA and many partners in the Democratic Republic of Congo, Ghana, Kenya, Malawi, Mozambique, Nigeria, Rwanda and Zimbabwe.

Email: [n2africa.office@wur.nl](mailto:n2africa.office@wur.nl)  
Internet: [www.N2Africa.org](http://www.N2Africa.org)

Authors of this report and contact details

Name: Andrew Farrow GeAgrofia  
Address: Wageningen, The Netherlands  
E-mail: andrewfarrow72@gmail.com

If you want to cite a report that originally was meant for use within the project only, please make sure you are allowed to disseminate or cite this report. If so, please cite as follows:

Andrew Farrow, 2014. Review of conditioning factors and constraints to legume adoption and their management in Phase II of N2Africa, [www.N2Africa.org](http://www.N2Africa.org), 22 pp.



Disclaimer:

This publication has been funded by the Bill & Melinda Gates Foundation through a grant to Wageningen University entitled "Putting nitrogen fixation to work for smallholder farmers in Africa". Its content does not represent the official position of Bill & Melinda Gates Foundation, Wageningen University or any of the other partner organisations within the project and is entirely the responsibility of the authors.

This information in this document is provided as it is and no guarantee or warranty is given that the information is fit for any particular purpose. The user thereof uses the information at their own sole risk and liability.



## Table of contents

<b>Short summary .....</b>	<b>4</b>
<b>Keywords.....</b>	<b>4</b>
<b>1 Introduction.....</b>	<b>4</b>
<b>2 Methodology .....</b>	<b>6</b>
2.1 Search universe and criteria.....	6
2.2 Potential constraints to adoption .....	6
2.3 Assessment of constraints.....	7
<b>3 Results.....</b>	<b>8</b>
3.1 Constraints to adoption of legumes.....	8
3.2 Frameworks for organising constraints to adoption .....	9
<b>4 Discussion and country-level application .....</b>	<b>11</b>
<b>References .....</b>	<b>13</b>
Reviewed literature:.....	13
Other References .....	16
<b>Appendix 1: Review matrix.....</b>	<b>17</b>
<b>List of project reports .....</b>	<b>19</b>

## Table of tables

Table 3.1: List of issues and the number of papers mentioning the issues as constraints to adoption..	8
Table 4.1: Constraints to the adoption of BNF technologies and practices and the management of these constraints in the research design .....	11

## Table of figures

Figure 3.1: Filters that technologies need to pass through to favour adoption (Haigis <i>et al.</i> 1998 in Schlecht <i>et al.</i> 2006) .....	9
--	---



## Short summary

In this paper I report the results of a review of literature focussing on the adoption of legume technologies in Africa by smallholder farmers. I extract from 53 studies the factors that are mentioned as constraints or pre-requisites to the adoption of legumes and the frameworks that are used to organise these factors. Finally I develop a matrix showing the spatial scales at which the constraints or factors operate and suggest ways of managing these in the research design of Phase II of N2Africa.

## Keywords

Adoption, legumes, conditioning factors, stratification, Africa, constraints, research design

## 1 Introduction

The first phase of N2Africa has shown that grain legume yield and successful biological nitrogen fixation (BNF) by legumes in the field depends on the interaction:

$$(G_L \times G_R) \times E \times M$$

where  $G_L$  is the legume genotype;  $G_R$  is the strain of rhizobium;  $E$  is a set of conditioning factors on  $G_L$  (and  $G_R$ ) and includes soils (limiting nutrients, toxicity, soil texture, physical barriers etc.), temperature, solar radiation and rainfall during the growing season, pests and diseases;  $M$  is the management of the crop, the rhizobium and the local (farm scale) manipulation of the environment (Ronner and Franke, 2012).

Grain legume yield and biological nitrogen fixation over a large area – say a country – depends on adoption of legumes for a sustained time period, and is conceptually more complicated than the plot level management of plant, soil, climate and rhizobia. Nevertheless it is possible to capture the conditions surrounding the adoption of legume technologies and impact of BNF at scale by the following interaction:

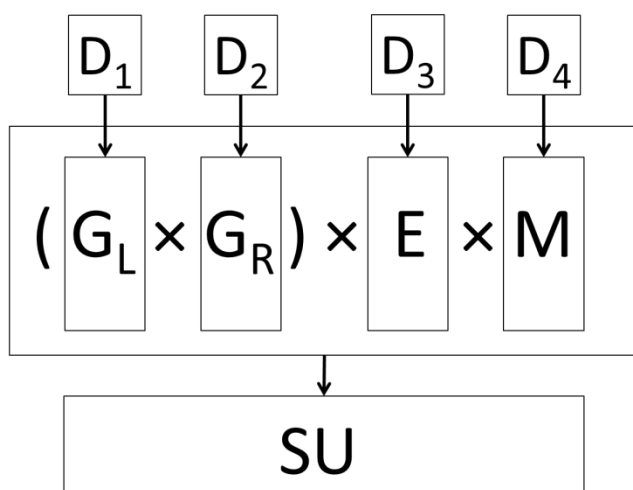

where  $D_1$  is the delivery of / availability of legume genotypes;  $D_2$  is the delivery of / availability of strains of rhizobium;  $D_3$  is the delivery / availability of other inputs;  $D_4$  is the delivery of / knowledge of management practices, and;  $SU$  is the marketing for sale and utilisation of the legume crop.



---

All of the components of the conceptual framework above will need to be considered in the research design of Phase II of N2Africa, but more information is required on the specific constraints to adoption of grain legumes in Africa. This information can be extracted from a review of the numerous studies of legumes and other crops in Africa and the developing world, which have assessed the factors that promote or hinder adoption.

This review builds on the conceptual framework above and has two objectives: (1) to assess the relative importance of different factors that positively affect or constrain the adoption of legumes at different levels; and (2) how these factors or constraints can be organised practically to develop the conceptual framework above.



## 2 Methodology

I reviewed peer-review journal articles and book chapters, as well as grey literature that is relevant to the countries in question or to the adoption of legume technologies.

This assessment was guided by an *a priori* list of potential constraints but with the possibility of adding unanticipated barriers to adoption and utilisation. The frequency of each type of constraint will be recorded and a narrative will be written which describes the importance of the constraints.

Potential confounding factors were also assessed and the basic spatial units defined. As a result of this review recommendations for strata were made that could be incorporated in the research design for N2Africa in Ethiopia, Uganda and Tanzania.

### 2.1 Search universe and criteria

The search universe for the assessment of past research included peer reviewed articles that were listed in the Scopus database. Where relevant, snowball sampling from citations in key texts was used to add manuscripts to the list. In addition grey literature from N2Africa was reviewed although with an emphasis on the lessons learned from Phase I with regard to adoption constraints and on the specific conditions in Ethiopia, Uganda and Tanzania that affect adoption and utilisation of legume technologies.

The search criteria within Scopus was “legume” AND “adoption”, which resulted in 318 documents. These were reviewed and were chosen subjectively based on the document title, giving 32 documents. A further 21 documents cited in these texts were deemed relevant and were added to the list for evaluation.

A matrix was developed in MSExcel with full citation, and abstract (where appropriate), each paper was classified (Annex 1) according to whether the paper addressed legumes and if so what species or function in the farming system (e.g. forage legumes).

### 2.2 Potential constraints to adoption

The initial list of potential constraints to the adoption of legume technologies consisted of the following:

- Availability of labour
- Availability of (legume) seed
- Knowledge about the technology or practice
- Household access to Capital / Assets
- Output market for agricultural (legume) products
- Availability of other (non-seed) inputs
- Biophysical relevance of technology
- Collective action for marketing products, purchasing inputs or experimentation
- Agricultural Research and Development system (including extension)
- Gender
- Education / literacy of the farm household members
- Experience of the farm household members
- Land availability, quality or tenure
- Cultural factors
- Alternative technologies or livelihoods that compete with the technology
- Government support



## 2.3 Assessment of constraints

Each of the issues was scored if mentioned in the text as a constraint to the adoption and utilisation of legume agricultural technologies. In addition notes were made of comments in the manuscript which were very pertinent, or of frameworks that could be used in the context of organising constraints.



## 3 Results

Of the 53 articles assessed all but six included research from Africa, of these five included experiences from Ethiopia, seven from Tanzania and four from Uganda.

### 3.1 Constraints to adoption of legumes

All of the issues in the list were mentioned as a factor hindering the adoption of technologies at least six times (Table 3.1). In addition the following constraints were added during the assessment:

- Adaptability of technology
- Risk Perceptions
- Opportunity cost / time lag to benefits

The most commonly mentioned constraints were the biophysical relevance of the technology or practice (such as suitability for the agro-ecological zone, or response to specific problems), followed by the effectiveness of the research and extension service, access to capital/assets (or credit).

**Table 3.1: List of issues and the number of papers mentioning the issues as constraints to adoption**

Constraint	Number of papers
Biophysical relevance of technology	25
Agricultural Research and Development system (including extension)	23
Household access to Capital / Assets	22
Availability of (legume) seed	22
Knowledge about the technology or practice	22
Land availability, quality or tenure	21
Output market for agricultural (legume) products	18
Availability of labour	15
Collective action for marketing products, purchasing inputs or experimentation	12
Alternative technologies or livelihoods that compete with the technology	11
Gender	10
Availability of other (non-seed) inputs	10
Risk Perceptions	9
Opportunity cost / time lag to benefits	9
Cultural factors	7
Government support	7
Education / literacy of the farm household members	6
Experience of the farm household members	6
Adaptability of technology	6





## 3.2 Frameworks for organising constraints to adoption

Particularly interesting articles included one by Ndah *et al.* (2012) which documented an approach for assessing conservation agriculture (Qualitative expert Assessment Tool for CA adoption in Africa - QAToCA) which could potentially be adapted for biological nitrogen fixation. QAToCA contains seven thematic areas: (A) the characteristics of the technology as an object of adoption; (B) the capacity of the organisation that is implementing the promotion of the technology; (C) the attributes of the diffusion strategy used; (D) the political and institutional framework of the country/region where the technology is being promoted; (E) the political and institutional framework of the village where the technology is being implemented; (F) conditions of the input and output markets at both village and regional level, and; (G) the attitude of the communities towards the technology and its adopters.

A paper on the adoption of improved fallows (Place and Dewees, 1999) also provided a useful framework of constraints at different levels and of different categories. The categories of constraints were the following: (A) Knowledge of natural resource problem; (B) Importance of the natural resource; (C) Willingness to invest; (D) Capacity to invest (E) Economic incentives, and; (F) Support services. Constraints were identified not just at the farm household level, but also at the plot level and at higher levels like the community and the region/national level. This framework is developed for technologies that address natural resource management problems, but perhaps is of less utility for the spatial stratification component of the research design of N2Africa because of the large emphasis placed on constraints at low levels. Nevertheless the framework could be a useful addition to the stratification and selection of communities, and farms.

The paper by Schlecht *et al.* (2006) on soil fertility restoration in the Sahel cites an interesting approach by Haigis *et al.* (1998) which proposes a series of filters through which a technology would need to pass in order to be tested (Figure 3.1). This approach is similar to the concept of socio-ecological niches (Ojiem *et al.*, 2006) which also proposes a hierarchical arrangement of factors (that affect adoption) which does not seek to filter out suitable technologies, but instead to match legume technologies to specific niches based on a combination of factors. This could be easily adapted for N2Africa, and the levels converted to strata in the sampling design

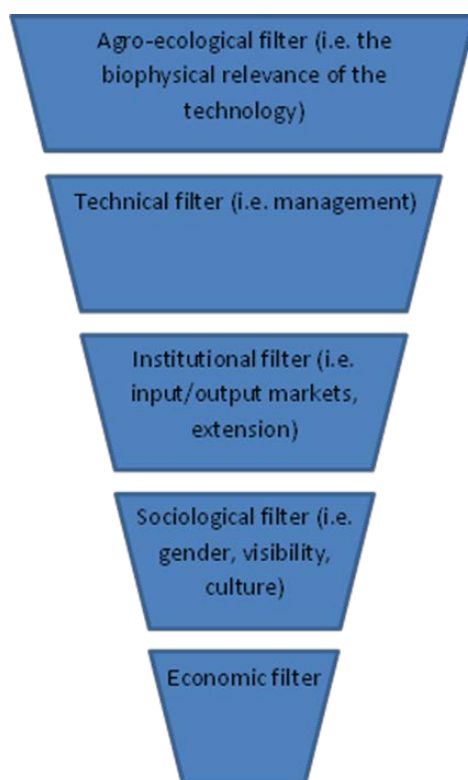

Figure 3.1: Filters that technologies need to pass through to favour adoption (Haigis *et al.* 1998 in Schlecht *et al.* 2006)



For forage legumes Shelton *et al.* (2005) report the opinion of numerous experts regarding the importance of different factors affecting adoption, they concluded that five key factors were important: the most important was (1) the technology meets a need of farmers, followed equally by; (2) the socio-economic situation of farmers; (3) the existence of stakeholder partnerships (including the private sector); (4) a commitment by these stakeholders over long periods; and (5) the implementation of an extension program focussing on the needs of farmers. The first factor in this list is similar to the biophysical relevance of the technology – essentially the G x E component of biological nitrogen fixation. Whereas the other factors are relate to the management component, the delivery of knowledge and availability of inputs, although the existence of functioning output markets was not considered, perhaps because the forage legume technology is an input into animal production.

Another paper which was useful in the context of testing BNF at scale was by Serrine *et al.* (2010) which concentrated on the adoption potential of agroforestry technologies. The authors cite an approach by Franzel *et al.* (2002) which also investigated the adoption potential of agroforestry, and which identified six factors: (1) Biophysical performance; (2) Profitability; (3) Feasibility and acceptability; (4) Boundary conditions; (5) Lessons for effective dissemination: extension and policy, and; (6) Feedback to research and extension.

Serrine *et al.* (2002) concentrate on the last four of these factors and conclude that a combination of both *ex ante* and *ex post* analysis of constraints to adoption are needed. This implies that the Phase II research design for N2Africa should consider not just the theoretical constraints to adoption (considered in this review) but should also draw lessons from the monitoring and evaluation, early adoption and impact studies from Phase I.

Sumberg (2005) looks more broadly at the adoption of agricultural innovations, and links this with constraints to farm productivity and constraints to the impact of agricultural research. The author develops the proposition further and considers interactions between the innovation and the user which addresses the demand or the potential benefit, as well as the performance and feasibility of the innovation. The second interaction is among the innovation, the user and the context; this looks at issues like land labour, and availability of inputs. The third interaction is between the innovation and the context, and considers output markets and the policy and institutional frameworks. The author proposes that only the first interaction is considered as a constraint to adoption whereas the factors in the last two interactions are 'prerequisite conditions' without which there should be no expectation of adoption, and which are outside the control of the innovation development process. This separation of endogenous and exogenous factors is important for the research design of N2Africa in Ethiopia, Uganda and Tanzania and an effort should be made to define those apparently exogenous factors which can be influenced by N2Africa – such as seed systems and knowledge delivery – and those, like market infrastructure and the climate, which cannot.

The final set of comments is from Tiftonell *et al.* (2012), who while investigating conservation agriculture (CA) conclude that "There are no universally significant factors that affect CA adoption" (pg. 169). Nevertheless, the authors suggest that approaches to promoting CA should include some common elements such as education, social capital building, technical and financial assistance. The experience from other technologies and cases reviewed here suggests that, at broad levels at least, there are factors which appear to be universally significant in the adoption of agricultural technologies and which should be incorporated in the research design of N2Africa Phase II.



## 4 Discussion and country-level application

The different constraints to adoption can be classified according to the component of biological nitrogen fixation which they hinder and - following Sumberg (2005) - the category of interaction between the user the innovation and the context that they represent (Table 4.1). These categories, along with the scale or level at which they act, determines how the constraints can be dealt with in the research design of Phase II of N2Africa.

Options for management of these constraints includes stratification of those constraints that cannot be controlled but which will have an effect on the 'fit' of different legume technologies and practices, and the subsequent diversity of options. These constraints include the climate and some general soil parameters, and to a certain extent land tenure and average land sizes, as well as some household/farm attributes.

For other constraints there exists the opportunity to test different mechanisms relating to the delivery and generation of knowledge and training, different models of seed multiplication and diffusion, the production, marketing and delivery of rhizobia and other inputs, and the community level the different models of selling and adding value to legume products.

A third category of constraints require monitoring and operate at levels which preclude stratification or operate in ways that are dynamic, difficult to predict and therefore difficult to stratify. These include government support or regulatory framework around inoculants, fertilisers, seed movement, seed certification, and agricultural development, extension and research priorities. A sub-set of constraints act at the household level and might not become apparent until the project is underway; these should be monitored and their effects evaluated during the course of the project.

**Table 4.1: Constraints to the adoption of BNF technologies and practices and the management of these constraints in the research design**

Constraint	BNF Component	Category	Scale / level of constraint	Management of constraint in research design
Biophysical relevance of technology	$(G_L \times G_R) \times E$	innovation x context	Multiple	Stratify
Agricultural Research and Development system (including extension)	$D_4$	innovation x user x context	National, but variations in coverage	Test
Household access to Capital / Assets	$M, D_1, D_2, D_3$	innovation x user	Household	Stratify
Availability of (legume) seed	$D_1$	innovation x context	Multiple, but thresholds determined by farmers' time and cost of transport	Pre-requisite / Test
Knowledge about the technology or practice	$D_4$	innovation x user	Multiple	Pre-requisite / Test
Land availability, quality or tenure	$E, M$	innovation x user x context	Multiple	Stratify
Output market for agricultural (legume) products	$SU$	innovation x context	Multiple	Pre-requisite / Stratify



Availability of labour	M	innovation x user x context	Household and Community	Stratify
Collective action for marketing products, purchasing inputs or experimentation	SU	innovation x context	Household and Community	Test
Alternative technologies or livelihoods that compete with the technology	M	innovation x user	Multiple	Monitor
Gender	M, ( $G_L \times G_R$ )	innovation x user x context	Household and Community level	Stratify
Availability of other (non-seed) inputs	( $G_L \times G_R$ ) x E	innovation x context	Multiple, but thresholds determined by farmers' time and cost of transport	Pre-requisite / Test
Risk Perceptions	M	innovation x user	Household and Community	Monitor
Opportunity cost / time lag to benefits	M, ( $G_L \times G_R$ )	innovation x user	Household	Monitor
Cultural factors	M, ( $G_L \times G_R$ )	innovation x user x context	Household and Community level	Monitor
Government support	$D_1, D_2, D_3, D_4, SU$	innovation x context	National, but some local policies may be relevant to adoption	Monitor
Education / literacy of the farm household members	M, ( $G_L \times G_R$ )	innovation x user x context	Household and Community	Stratify
Experience of the farm household members	M, ( $G_L \times G_R$ )	innovation x user x context	Household	Stratify
Adaptability of technology	M	innovation x user	Household and Community	Monitor

Future reports will address the countries of Ethiopia, Tanzania and Uganda and review the general areas where N2Africa will work, the legume crops that have been chosen and the partners who are likely to be involved. Given these boundary conditions the needs for characterisation and options for stratification will be discussed.



## References

### Reviewed literature:

- 1 - Abate, T., Shiferaw, B., Gebeyehu, S., Amsalu, B., Negash, K., Assefa, K., Eshete, M., Aliye, S. & Hagmann, J. 2011. A systems and partnership approach to agricultural research for development: Lessons from Ethiopia. *Outlook on AGRICULTURE*, 40, 213-220.
- 2 - Adisa, R. S. & Balogun, K. S. 2013. Impact of improved technologies on small-scale soybean production: Empirical evidence from Benue state, Nigeria. *Pakistan Journal of Agricultural Sciences*, 50, 305-310.
- 3 - Ajayi, O. C., Akinnifesi, F. K., Sileshi, G. & Chakeredza, S. 2007. Adoption of renewable soil fertility replenishment technologies in the southern African region: Lessons learnt and the way forward. *Natural Resources Forum*, 31, 306-317.
- 4 - Ajeigbe, H. A., Singh, B. B., Adeosun, J. O. & Ezeaku, I. E. 2010. Participatory on-farm evaluation of improved legume-cereals cropping systems for crop-livestock farmers: Maize-double cowpea in Northern Guinea Savanna Zone of Nigeria. *African Journal of Agricultural Research*, 5, 2080-2088.
- 5 - Aker, J. C. 2011. Dial "A" for agriculture: A review of information and communication technologies for agricultural extension in developing countries. *Agricultural Economics*, 42, 631-647.
- 6 - Alene, A. D. & Manyong, V. M. 2006. Endogenous technology adoption and household food security: The case of improved cowpea varieties in northern Nigeria. *Quarterly Journal of International Agriculture*, 45, 211-230.
- 7 - AmarE, M., Asfaw, S. & Shiferaw, B. 2012. Welfare impacts of maize-pigeonpea intensification in Tanzania. *Agricultural Economics*, 43, 27-43.
- 8 - Asfaw, S., Shiferaw, B., Simtowe, F. & Lipper, L. 2012. Impact of modern agricultural technologies on smallholder welfare: Evidence from Tanzania and Ethiopia. *Food Policy*, 37, 283-295.
- 9 - Ayele, Z. 2003. Community-based forage development program: The experiences of Farm Africa Goat Project in Ethiopia. *Tropical Grasslands*, 37, 257-261.
- 10 - Bamire, A. S., Fabiyi, Y. L. & Manyong, V. M. 2002. Adoption pattern of fertiliser technology among farmers in the ecological zones of south-western Nigeria: A Tobit analysis. *Australian Journal of Agricultural Research*, 53, 901-910.
- 11 - Banadda, N. 2010. Gaps, barriers and bottlenecks to sustainable land management (SLM) adoption in Uganda. *African Journal of Agricultural Research*, 5, 3571-3580.
- 12 - Bantilan, M. C. S. & Johansen, C. 1995. Research evaluation and impact analysis of biological nitrogen fixation. *Plant and Soil*, 174, 279-286.
- 13 - Bohlool, B. B., Ladha, J. K., Garrity, D. P. & George, T. 1992. Biological nitrogen fixation for sustainable agriculture: A perspective. *Plant and Soil*, 141, 1-11.
- 14 - Boys, K., Faye, M., Fulton, J. & Lowenberg-Deboer, J. 2007. The economic impact of cowpea research in Senegal: An ex-post analysis with disadoption. *Agricultural Economics*, 36, 363-375.
- 15 - Chianu, J. N., Nkonya, E. M., Mairura, F. S., Chianu, J. N. & Akinnifesi, F. K. 2011. Biological nitrogen fixation and socioeconomic factors for legume production in sub-Saharan Africa: a review. *Agronomy for Sustainable Development*, 31, 139-154.
- 16 - David, S., Mukandala, L. & Mafuru, J. 2002. Seed availability, an ignored factor in crop varietal adoption studies: A case study of beans in Tanzania. *Journal of Sustainable Agriculture*, 21, 5-20.
- 17 - David, S. & Sperling, L. 1999. Improving technology delivery mechanisms: Lessons from bean seed systems research in eastern and central Africa. *Agriculture and Human Values*, 16, 381-388.



- 18 - El Wakeel, A. & Astatke, A. 1996. Intensification of agriculture on vertisols to minimize land degradation in parts of the Ethiopian Highlands. *Land Degradation and Development*, 7, 57-67.
- 19 - Erbaugh, J. M., Donnermeyer, J., Amujal, M. & Kidoido, M. 2010. Assessing the impact of farmer field school participation on IPM adoption in Uganda. *Journal of International Agricultural and Extension Education*, 17, 5-18.
- 20 - Freeman, H. A., Van Der Merwe, P. J. A., Subrahmanyam, P., Chiyembekeza, A. J. & Kaguongo, W. 2002. Assessing adoption potential of new groundnut varieties in Malawi. *Experimental Agriculture*, 38, 211-221.
- 21 - Honlonkou, A. N., Manyong, V. M. & Tchetché, N. 1999. Farmers' perceptions and the dynamics of adoption of a resource management technology: The case of Mucuna fallow in southern Benin, West Africa. *International Forestry Review*, 1, 228-235.
- 22 - Jones, R. B. & Rakotoarisaona, J. J. 2007. Supporting the development of sustainable seed systems for nonhybrid crops. *Acta Horticulturae*.
- 23 - Kamanga, B. C. G., Kanyama-Phiri, G. Y., Waddington, S. R., Almekinders, C. J. M. & Giller, K. E. 2014. The evaluation and adoption of annual legumes by smallholder maize farmers for soil fertility maintenance and food diversity in central Malawi. *Food Security*, 6 (1), 45-59.
- 24 - Kerr, R. B., Snapp, S., Chirwa, M., Shumba, L. & Msachi, R. 2007. Participatory research on legume diversification with Malawian smallholder farmers for improved human nutrition and soil fertility. *Experimental Agriculture*, 43, 437-453.
- 25 - Kristjanson, P., Place, F., Franzel, S. & Thornton, P. K. 2002. Assessing research impact on poverty: The importance of farmers' perspectives. *Agricultural Systems*, 72, 73-92.
- 26 - Mafongoya, P. L., Bationo, A., Kihara, J. & Waswa, B. S. 2006. Appropriate technologies to replenish soil fertility in southern Africa. *Nutrient Cycling in Agroecosystems*, 76, 137-151.
- 27 - Mhango, W. G., Snapp, S. S. & Phiri, G. Y. K. 2013. Opportunities and constraints to legume diversification for sustainable maize production on smallholder farms in Malawi. *Renewable Agriculture and Food Systems*, 28, 234-244.
- 28 - Morse, S. & McNamara, N. 2003. Factors affecting the adoption of leguminous cover crops in Nigeria and a comparison with the adoption of new crop varieties. *Experimental Agriculture*, 39, 81-97.
- 29 - Mugwe, J., Mucheru-Muna, M., Mugendi, D., Kung'u, J., Bationo, A. & Mairura, F. 2009. Adoption potential of selected organic resources for improving soil fertility in the central highlands of Kenya. *Agroforestry Systems*, 76, 467-485.
- 30 - Ndah, H. T., Schuler, J., Uthes, S., Zander, P., Triomphe, B., Mkomwa, S. & Corbeels, M. 2012. Adoption potential for conservation agriculture in Africa: A newly developed assessment approach (QAToCA) applied in Kenya and Tanzania. *Land Degradation and Development*. DOI: 10.1002/ldr.2191
- 31 - Nyemeck Binam, J., Abdoulaye, T., Olarinde, L., Kamara, A. & Adekunle, A. 2011. Assessing the potential impact of integrated agricultural research for development (IAR4D) on adoption of improved cereal-legume crop varieties in the Sudan Savannah zone of Nigeria. *Journal of Agricultural and Food Information*, 12, 177-198.
- 32 - Nyende, P. & Delve, R. J. 2004. Farmer participatory evaluation of legume cover crop and biomass transfer technologies for soil fertility improvement using farmer criteria, preference ranking and logit regression analysis. *Experimental Agriculture*, 40, 77-88.
- 33 - Okalebo, J. R., Othieno, C. O., Woome, P. L., Karanja, N. K., Semoka, J. R. M., Bekunda, M. A., Mugendi, D. N., Muasya, R. M., Bationo, A. & Mukhwana, E. J. 2006. Available technologies to replenish soil fertility in East Africa. *Nutrient Cycling in Agroecosystems*, 76, 153-170.
- 34 - Place, F. & Dewees, P. 1999. Policies and incentives for the adoption of improved fallows. *Agroforestry Systems*, 47, 323-343.





- 35 - Schlecht, E., Buerkert, A., Tielkes, E. & Bationo, A. 2006. A critical analysis of challenges and opportunities for soil fertility restoration in Sudano-Sahelian West Africa. *Nutrient Cycling in Agroecosystems*, 76, 109-136.
- 36 - Shelton, H. M., Franzel, S. & Peters, M. 2005. Adoption of tropical legume technology around the world: Analysis of success. *Tropical Grasslands*, 39, 198-209.
- 37 - Shiferaw, B., Obare, G. & Muricho, G. 2008. Rural market imperfections and the role of institutions in collective action to improve markets for the poor. *Natural Resources Forum*, 32, 25-38.
- 38 - Shiferaw, B. A., Kebede, T. A. & YOU, L. 2008. Technology adoption under seed access constraints and the economic impacts of improved pigeonpea varieties in Tanzania. *Agricultural Economics*, 39, 309-323.
- 39 - Siddique, K. H. M., Johansen, C., Turner, N. C., Jeuffroy, M. H., Hashem, A., Sakar, D., Gan, Y. & Alghamdi, S. S. 2012. Innovations in agronomy for food legumes. A review. *Agronomy for Sustainable Development*, 32, 45-64.
- 40 - Sileshi, G., Akinnifesi, F. K., Debusho, L. K., Beedy, T., Ajayi, O. C. & Mong'omba, S. 2010. Variation in maize yield gaps with plant nutrient inputs, soil type and climate across sub-Saharan Africa. *Field Crops Research*, 116, 1-13.
- 41 - Simtowe, F., Kassie, M., Diagne, A., Asfaw, S., Shiferaw, B., Silim, S. & Muange, E. 2011. Determinants of agricultural technology adoption: The case of improved pigeonpea varieties in Tanzania. *Quarterly Journal of International Agriculture*, 50, 325-345.
- 42 - SIRRINE, D., SHENNAN, C. & SIRRINE, J. R. 2010. Comparing agroforestry systems' ex ante adoption potential and ex post adoption: On-farm participatory research from southern Malawi. *Agroforestry Systems*, 79, 253-266.
- 43 - Snapp, S., Kanyama-Phiri, G., Kamanga, B., Gilbert, R. & Wellard, K. 2002. Farmer and researcher partnerships in Malawi: Developing soil fertility technologies for the near-term and far-term. *Experimental Agriculture*, 38, 411-431.
- 44 - Snapp, S. S., Rohrbach, D. D., Simtowe, F. & Freeman, H. A. 2002. Sustainable soil management options for Malawi: Can smallholder farmers grow more legumes? *Agriculture, Ecosystems and Environment*, 91, 159-174.
- 45 - Spielman, D. J., Davis, K., Negash, M. & Ayele, G. 2011. Rural innovation systems and networks: Findings from a study of Ethiopian smallholders. *Agriculture and Human Values*, 28, 195-212.
- 46 - Sumberg, J. 2005. Constraints to the adoption of agricultural innovations: Is it time for a re-think? *Outlook on AGRICULTURE*, 34, 7-10.
- 47 - Tarawali, G., Iyangbe, C., Udensi, U. E., Ilona, P., Osun, T., Okater, C. & Asumugha, G. N. 2012. Commercial-scale adoption of improved cassava varieties: A baseline study to highlight constraints of large-scale cassava based agro-processing industries in Southern Nigeria. *Journal of Food, Agriculture and Environment*, 10, 689-694.
- 48 - Thapa, G. B. & Yila, O. M. 2012. Farmers' land management practices and status of agricultural land in the Jos plateau, Nigeria. *Land Degradation and Development*, 23, 263-277.
- 49 - Thierfelder, C., Cheesman, S. & Rusinamhodzi, L. 2013. Benefits and challenges of crop rotations in maize-based conservation agriculture (CA) cropping systems of southern Africa. *International Journal of Agricultural Sustainability*, 11, 108-124.
- 50 - Tittonell, P., Scopel, E., Andrieu, N., Posthumus, H., Mapfumo, P., Corbeels, M., Van Halsema, G. E., Lahmar, R., Lugandu, S., Rakotoarisoa, J., Mtambanengwe, F., Pound, B., Chikowo, R., Naudin, K., Triomphe, B. & Mkomwa, S. 2012. Agroecology-based aggradation-conservation agriculture (ABACO): Targeting innovations to combat soil degradation and food insecurity in semi-arid Africa. *Field Crops Research*, 132, 168-174.



- 
- 51 - Wambugu, C., Place, F. & Franzel, S. 2011. Research, development and scaling up the adoption of fodder shrub innovations in East Africa. *International Journal of Agricultural Sustainability*, 9, 100-109.
- 52 - Weber, G. 1996. Legume-based technologies for African savannas: Challenges for research and development. *Biological Agriculture and Horticulture* 13(4): 309-333.
- 53 - Zander, K. K., Mwacharo, J. M., Drucker, A. G. & Garnett, S. T. 2013. Constraints to effective adoption of innovative livestock production technologies in the Rift Valley (Kenya). *Journal of Arid Environments*, 96, 9-18.

## Other References

- Ronner, E., & Franke, A.C., 2012. Quantifying the impact of the N2Africa project on biological nitrogen fixation. [www.N2Africa.org](http://www.N2Africa.org)
- Ojiem, J.O., De Ridder, N., Vanlauwe, B. & Giller K. E. 2006. Socio-ecological niche: a conceptual framework for integration of legumes in smallholder farming systems. *International Journal of Agricultural Sustainability*, 4(1), 79–93





## Appendix 1: Review matrix

- |                     |                            |  |
|---------------------|----------------------------|--|
| A. Africa           | I. Output market           | Q. Land availability, quality or tenure    |
| B. Ethiopia         | J. Other inputs            | R. Cultural factors                        |
| C. Tanzania         | K. Relevance of technology | S. Alternative technologies or livelihoods |
| D. Uganda           | L. Collective action       | T. Government support                      |
| E. Labour           | M. ARD system              | U. Adaptability of technology              |
| F. Seed             | N. Gender                  | V. Risk Perceptions                        |
| G. Knowledge        | O. Education               | W. Opportunity cost / time lag to benefits |
| H. Capital / Assets | P. Experience              |  |

Study #	Legumes	Location				Constraints																				
		A	B	C	D	E	F	G	H	I	J	K	L	M	N	O	P	Q	R	S	T	U	V	W		
1	Common Bean, Chickpea, Lentil	1	1							1		1	1	1												
2*	Soybean	1				1		1	1		1				1	1	1									
3	Green manure & dual purpose legumes	1							1	1	1	1		1				1	1	1	1	1				
4	cowpea	1						1	1	1		1	1	1												
5									1					1												
6	cowpea	1						1	1		1					1		1								
7	pigeonpea	1		1		1	1	1	1					1			1	1			1					
8	chickpea, pigeonpea	1	1	1		1	1	1	1			1	1	1												
9	forage legumes	1	1								1	1	1								1					
10		1							1		1				1			1	1			1	1			
11		1			1									1				1	1				1			
12	rhizobium inoculation								1			1	1		1											
13	BNF								1	1		1									1	1				
14	cowpea	1							1	1	1		1													
15	rhizobium inoculation	1						1	1	1		1			1							1			1	
16	Common Bean	1		1				1			1		1					1								
17	Common Bean	1		1	1			1																	1	
18	forage legumes	1	1																							
19	cowpea	1			1	1			1	1				1				1			1			1		
20	groundnut	1						1					1													
21*	mucuna	1												1							1					
22	legumes	1						1																		
23	grain legumes & green	1				1	1				1													1	1	





## List of project reports

1. N2Africa Steering Committee Terms of Reference
2. Policy on advanced training grants
3. Rhizobia Strain Isolation and Characterisation Protocol
4. Detailed country-by-country access plan for P and other agro-minerals
5. Workshop Report: Training of Master Trainers on Legume and Inoculant Technologies (Kisumu Hotel, Kisumu, Kenya-24-28 May 2010)
6. Plans for interaction with the Tropical Legumes II project (TLII) and for seed increase on a country-by-country basis
7. Implementation Plan for collaboration between N2Africa and the Soil Health and Market Access Programs of the Alliance for a Green Revolution in Africa (AGRA) plan
8. General approaches and country specific dissemination plans
9. Selected soyabeans, common beans, cowpeas and groundnuts varieties with proven high BNF potential and sufficient seed availability in target impact zones of N2Africa Project
10. Project launch and workshop report
11. Advancing technical skills in rhizobiology: training report
12. Characterisation of the impact zones and mandate areas in the N2Africa project
13. Production and use of rhizobial inoculants in Africa
18. Adaptive research in N2Africa impact zones: Principles, guidelines and implemented research campaigns
19. Quality assurance (QA) protocols based on African capacities and international existing standards developed
20. Collection and maintenance of elite rhizobial strains
21. MSc and PhD status report
22. Production of seed for local distribution by farming communities engaged in the project
23. A report documenting the involvement of women in at least 50% of all farmer-related activities
24. Participatory development of indicators for monitoring and evaluating progress with project activities and their impact
25. Suitable multi-purpose forage and tree legumes for intensive smallholder meat and dairy industries in East and Central Africa N2Africa mandate areas
26. A revised manual for rhizobium methods and standard protocols available on the project website
27. Update on Inoculant production by cooperating laboratories
28. Legume Seed Acquired for Dissemination in the Project Impact Zones
29. Advanced technical skills in rhizobiology: East and Central African, West African and South African Hub
30. Memoranda of Understanding are formalized with key partners along the legume value chains in the impact zones
31. Existing rhizobiology laboratories upgraded
32. N2Africa Baseline report
33. N2Africa Annual country reports 2011



34. Facilitating large-scale dissemination of Biological Nitrogen Fixation
35. Dissemination tools produced
36. Linking legume farmers to markets
37. The role of AGRA and other partners in the project defined and co-funding/financing options for scale-up of inoculum (banks, AGRA, industry) identified
38. Progress Towards Achieving the Vision of Success of N2Africa
39. Quantifying the impact of the N2Africa project on Biological Nitrogen Fixation
40. Training agro-dealers in accessing, managing and distributing information on inoculant use
41. Opportunities for N2Africa in Ethiopia
42. N2Africa Project Progress Report Month 30
43. Review & Planning meeting Zimbabwe
44. Howard G. Buffett Foundation – N2Africa June 2012 Interim Report
45. Number of Extension Events Organized per Season per Country
46. N2Africa narrative reports Month 30
47. Background information on agronomy, farming systems and ongoing projects on grain legumes in Uganda
48. Opportunities for N2Africa in Tanzania
49. Background information on agronomy, farming systems and ongoing projects on grain legumes in Ethiopia
50. Special Events on the Role of Legumes in Household Nutrition and Value-Added Processing
51. Value chain analyses of grain legumes in N2Africa: Kenya, Rwanda, eastern DRC, Ghana, Nigeria, Mozambique, Malawi and Zimbabwe
52. Background information on agronomy, farming systems and ongoing projects on grain legumes in Tanzania
53. Nutritional benefits of legume consumption at household level in rural sub-Saharan Africa: Literature study
54. N2Africa Project Progress Report Month 42
55. Market Analysis of Inoculant Production and Use
56. Identified soyabean, common bean, cowpea and groundnut varieties with high Biological Nitrogen Fixation potential identified in N2Africa impact zones
57. A N2Africa universal logo representing inoculant quality assurance
58. M&E Workstream report
59. Improving legume inoculants and developing strategic alliances for their advancement
60. Rhizobium collection, testing and the identification of candidate elite strains
61. Evaluation of the progress made towards achieving the Vision of Success in N2Africa
62. Policy recommendation related to inoculant regulation and cross border trade
63. Satellite sites and activities in the impact zones of the N2Africa project
64. Linking communities to legume processing initiatives
65. Special events on the role of legumes in household nutrition and value-added processing
66. Media Events in the N2Africa project



- 67. Launch N2Africa Phase II – Report Uganda
- 68. Review of conditioning factors and constraints to legume adoption and their management in Phase II of N2Africa



## Partners involved in the N2Africa project



A2N



Bayero University Kano (BUK)



Caritas Rwanda



Diobass



Eglise Presbyterienne Rwanda



Resource Projects-Kenya



Sasakawa Global; 2000



Université Catholique de Bukavu



University of Nairobi MIRCEN



University of Zimbabwe

